



\* 6451 \*

1662511049.

www.polytech4u.com

polytech4u@gmail.com

6451

C16-M-406

BOARD DIPLOMA EXAMINATION, (C-16)  
MARCH/APRIL—2018  
DME—FOURTH SEMESTER EXAMINATION

PRODUCTION DRAWING

Time : 3 hours ]

[ Total Marks : 60

PART—A

5×4=20

**Instructions** : (1) Answer **all** questions.

(2) Each question carries **five** marks.

(3) Draw the following neatly with proportionate dimensions.

(4) Use of production drawing tables is allowed.

1. Calculate the values of the maximum and minimum limits for both shaft and hole 45 H8/d9, using the tables for tolerances and indicate the type of fit obtained.

2. Draw the tolerance character symbols for the following :

(a) Flatness

(b) Cylindricity

(c) Run-out

(d) Position

(e) Parallelism

www.polytech4u.com

polytech4u@gmail.com

3. Write the surface roughness grade numbers for the following roughness values ( $\mu\text{m}$ ) :

- (a) 25
- (b) 1.6
- (c) 12.5
- (d) 3.6
- (e) 0.1

4. Write the meaning of following symbols/specifications :

- (a) Fe 410 Cu K
- (b) 25C5B0
- (c) Stud AM 10 $\times$ 30, IS : 1862-P-4.6
- (d) Hex.bolt M20 $\times$ 1.2 $\times$ 75 N, IS : 1364-S-4.6
- (e) Splines 6 $\times$ 32 $\times$ 28, IS : 2327

**PART—B**

40

**Instructions** : (1) Answer *any one* question.

(2) Each question carries **forty** marks.

5. Study the given assembly drawing of the universal coupling shown in Fig. 1 :

- (a) Draw the part drawings for fork and centre block. 20
- (b) Select suitable fits and tolerances. 4

- (c) Prepare the process sheet for center block made CI. 7
- (d) Indicate the surface roughness symbols and geometrical tolerance symbols. 6
- (e) List out the materials and quantity of the components. 3

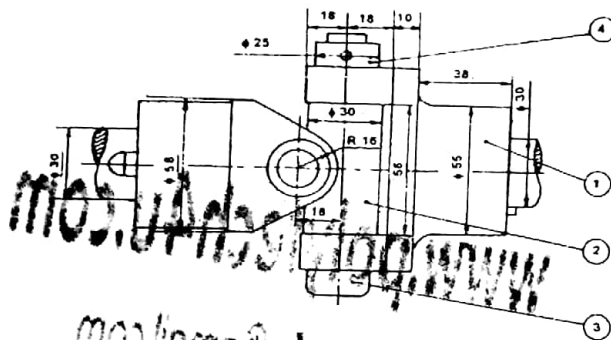
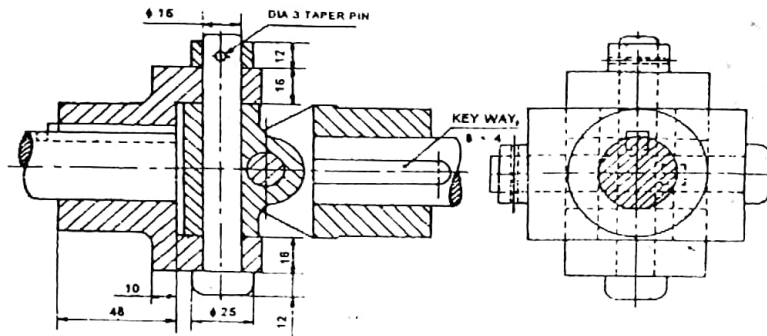

Bill of material

Part No.	Name	Raw material	Qty
1.	Fork		
2.	Centre block		
3.	Pin		
4.	Collar		

Universal Coupling

All dimensions are in mm

Fig. 1

6. Study the given assembly drawing of the clapper block shown in Fig. 2.

- (a) Draw the part drawings for clapper and tool holder. 20
- (b) Select suitable fits and tolerances. 4
- (c) Prepare the process sheet for tool holder made MS. 7
- (d) Indicate the surface roughness symbols and geometrical tolerance symbols. 6
- (e) List out the materials and quantity of the components. 3

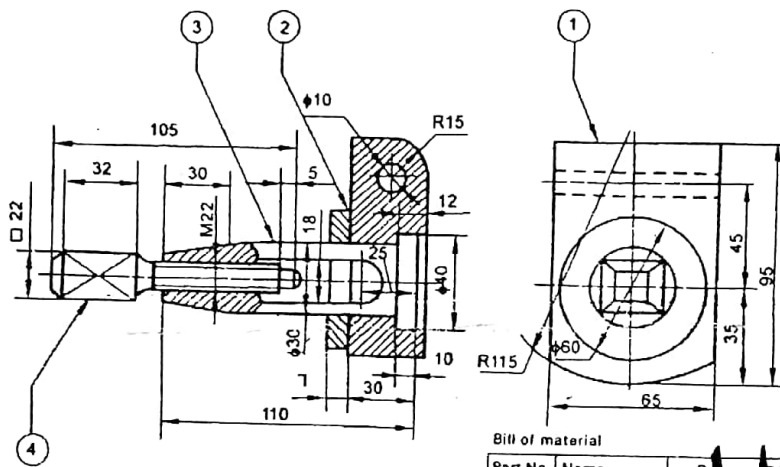

Bill of material

Part No	Name	Quantity
1	Clapper	1
2	Tool holder	1
3	Screw	1
4	Screw	1

www.polytech4u.com  
polytech4u@gmail.com

Clapper Block  
All dimensions are in mm  
Fig. 2  
\*\*\*